

NOTES:

(NI) 1. TO INSPECT ASSEMBLY, FOLLOW FIRST ARTICLE AND IN PROCESS INSPECTION SHEET.

2. APPLY LOCTITE 680 IF NYLON PATCH IS MISSING.

BILL OF MATERIAL (CURRENT LEVEL)				
ITEM	PT/ASSY	DESCRIPTION	TYPE	QTY.
1	6XXB	MOUNTING BRACKET	PART	2
2	1-206	HARDWARE PACK	ASSEMBLY	2
3	20-432	ESCUTCHEON ASM	ASSEMBLY	2
4	13172	POST, TT HOLDER LEFT	PART	1
5	92031	SCRW, M6 X 1 X 6 SKT HD CUP PT W/ SELF LOC SS	PART	4
6	10615	HEX KEY, 3MM ALLOY STEEL	PART	1
7	40663	ADAPTER	PART	2
8	91020	O-RING, #2-016, EPDM, 65-75 DURO, NSF 61	PART	2
9	13173	POST, TT HOLDER RIGHT	PART	1
10	7-737	TISSUE ROLLER ASM	ASSEMBLY	1

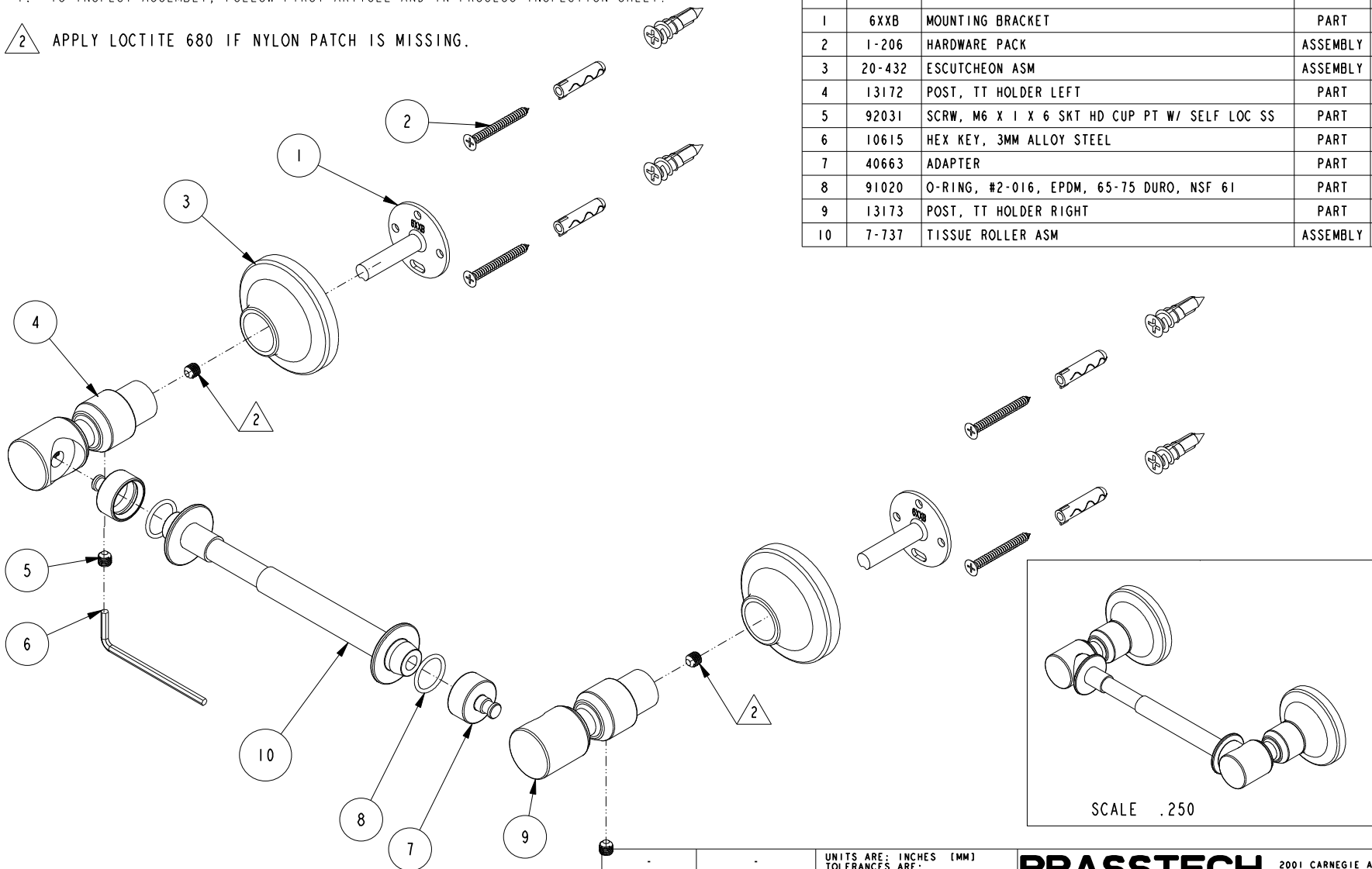

TESTING	-	-	-
ASSEMBLY	-	-	-
PLATING	-	-	-
POLISHING	-	NEXT ASSY	USED ON
MACHINING	-	APPLICATION	
TOOLING FIXTURE #	REMOVE ALL BURRS AND SHARP EDGES		

UNITS ARE: INCHES [MM]
 TOLERANCES ARE:
 FRACTIONS DECIMALS ANGLES
 $\pm 1/16"$.X $\pm .1$ [2.5] $\pm 1^\circ$
 .XX $\pm .06$ [1.5]

(X.XXX) DENOTES CRITICAL DIMS.
 ALL THREADS ARE CRITICAL

DRAWN MANJUNATH 05/14/19
 CHECKED JINSON 05/14/19
 APPROVED J.M. 05/14/19

BRASSTECH 2001 CARNEGIE AVE.
 INCORPORATED SANTA ANA, CA 92705
 (949) 417-5207

DOUBLE POST TT HOLDER

DWG NO. 3250-1530 REV A
 SCALE .375 REF. - SHEET 1 OF 2

COPYRIGHT 2005 BRASSTECH, INC.
 THESE DRAWINGS AND THE DESIGNS
 DEPICTED HEREIN ARE THE PROPRIETARY
 PROPERTY OF BRASSTECH. ANY USE
 OR REPRODUCTION IS SUBJECT TO
 THE EXPRESS APPROVAL OF BRASSTECH.
 UNAUTHORIZED USE IS STRICTLY
 PROHIBITED. ALL RIGHTS RESERVED.

-	A	EN-4221	08/21/20	J.M.
-	-	EN-3852	05/14/19	J.M.
ZONE	REV	DESCRIPTION	DATE	APPROVED

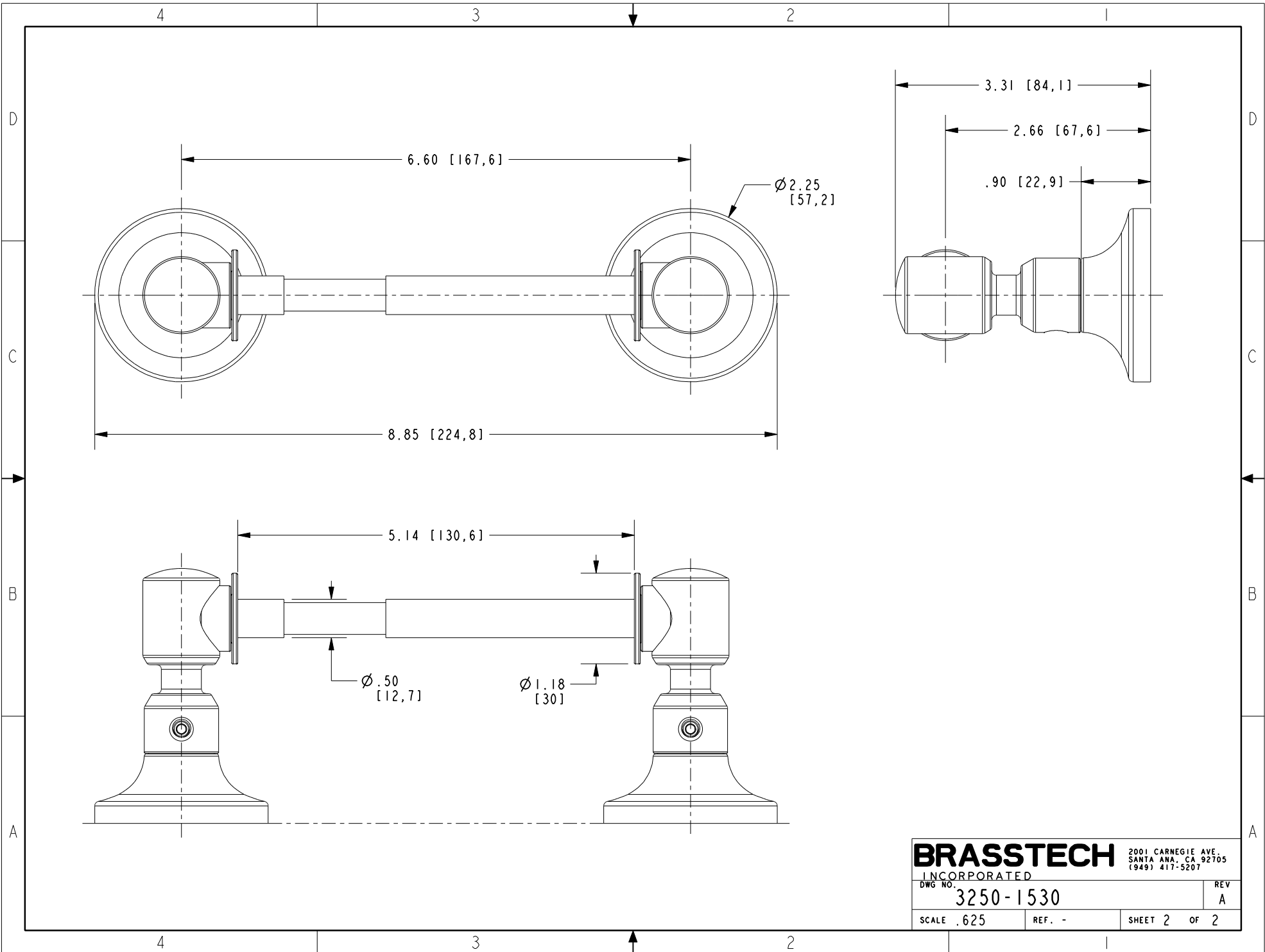

BRASSTECH		2001 CARNEGIE AVE. SANTA ANA, CA 92705 (949) 417-5207	
INCORPORATED			
DWG NO.	3250-1530	REV	A
SCALE .625	REF. -	SHEET 2	OF 2